

Additional Fluid In Tough Applications

The Unist Uni-Roller® S2 excels at applying a continuous even coating of fluid to coil stock or a blank. However, there are times when additional fluid is needed at specific areas in the die. Unist Airless Spray Nozzles provide this extra boost. When connected to the SmartFlow™ programmable fluid controller, they integrate seamlessly into the jobs lubrication profile.

- Versatile nozzle for in-die lubrication
- User-friendly design
- Requires no air to operate



Because these nozzles rely on the velocity of the fluid to create the spray pattern, their proper operation requires a fluid which is close to the viscosity of water. As a result, they work extremely well with water based solutions and emulsions, but are generally not recommended for use with oils or viscous synthetic fluids.

All Unist Airless Spray Nozzles have a fan spray pattern. The spray diameter and flow rate of the fluid are controlled by specifying the spray angle and the nozzle orifice size. The available spray angles and corresponding coverage are shown below.

Approximate spray dimensions					
B	W				
	0°	30°	50°	80°	110°
3" [76 mm]	stream	1.6" [41 mm]	2.8" [71 mm]	5.1" [130 mm]	8.6" [218 mm]
6" [152 mm]	stream	3.2" [81 mm]	5.6" [142 mm]	10.1" [257 mm]	17.1" [434 mm]
9" [229 mm]	stream	4.9" [124 mm]	10.0" [254 mm]	18.1" [460 mm]	30.4" [772 mm]
12" [305 mm]	stream	6.4" [163 mm]	11.2" [284 mm]	20.2" [513 mm]	34.3" [871 mm]
15" [381 mm]	stream	8.1" [206 mm]	14.0" [356 mm]	25.2" [640 mm]	42.8" [1087 mm]
18" [457 mm]	stream	9.7" [246 mm]	16.8" [427 mm]	30.3" [770 mm]	51.4" [1306 mm]

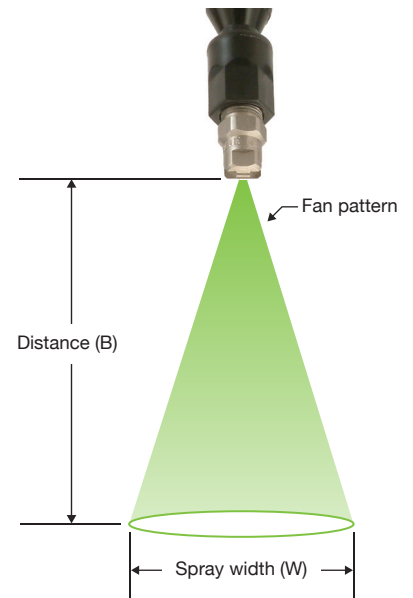

The available flow rates are:

Airless Spray Nozzle flow rate (based on water)	Orifice size	Flow rate range
	0.026" [0.66 mm]	2.21 cc/sec @ 5 psi [0.34 bar] to 10.1 cc/sec @ 100 psi [7 bar]
	0.031" [0.79 mm]	3.31 cc/sec @ 5 psi [0.34 bar] to 15.1 cc/sec @ 100 psi [7 bar]
	0.036" [0.91 mm]	4.42 cc/sec @ 5 psi [0.34 bar] to 20.2 cc/sec @ 100 psi [7 bar]

System Example

The Airless Spray Nozzles connect directly to the outputs on the SmartFlow™. Up to 22 nozzles can be independently controlled or used in combination with a Uni-Roller® S2 applicator, giving maximum flexibility in coverage and control.

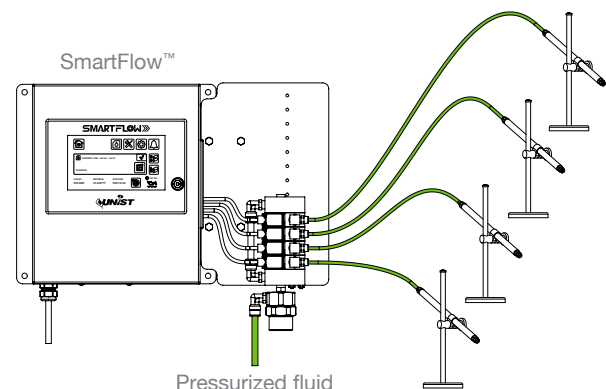

Nozzle Styles

Rigid Stainless Steel Nozzle

This 10" [254 mm] Rigid Stainless Steel Nozzle includes a vertical mount that allows height and application angles to be adjusted. The Rigid Stainless Steel Nozzle offers superior rigidity, making it the preferred choice when the nozzle position doesn't require frequent changes.

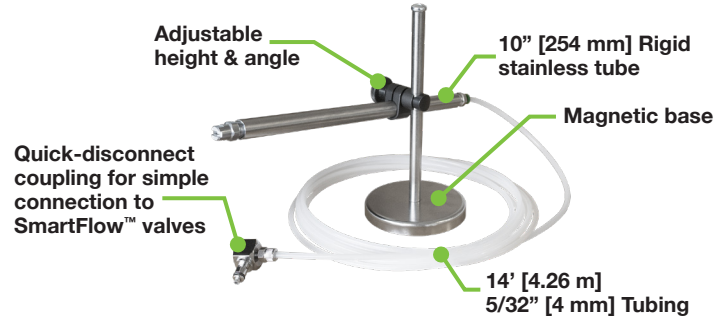

Loc-Line® Nozzle

This 12" [305 mm] flexible plastic Loc-Line® Nozzle is easy to adjust, but less rigid than the other nozzle options.

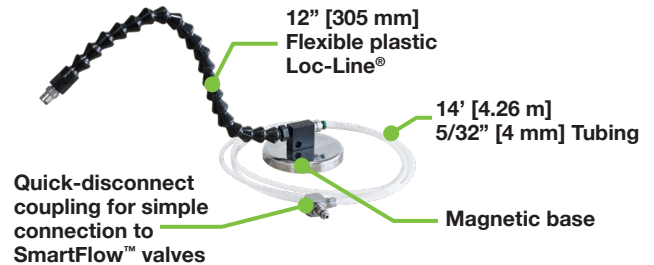

Articulating Arm Nozzle

The Articulating Arm Nozzle provides rigid positioning and can easily be adjusted and locked in place with one knob.

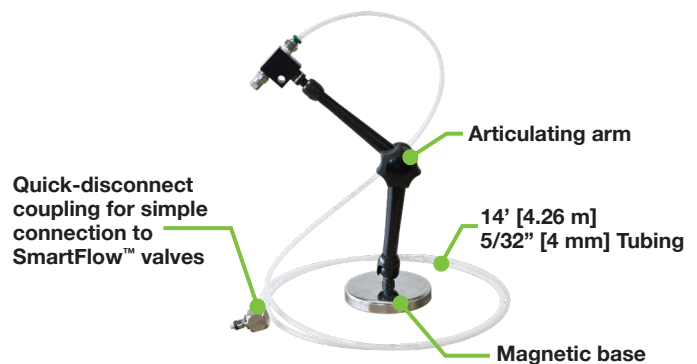

In-Die Nozzle

This nozzle rigidly attaches to the die. The slotted adjustment bracket allows for multiple nozzle positioning adjustments including nozzle height, fan spray orientation, rotation, and pivoting. Once positioned, it can be locked into position by tightening the hardware.

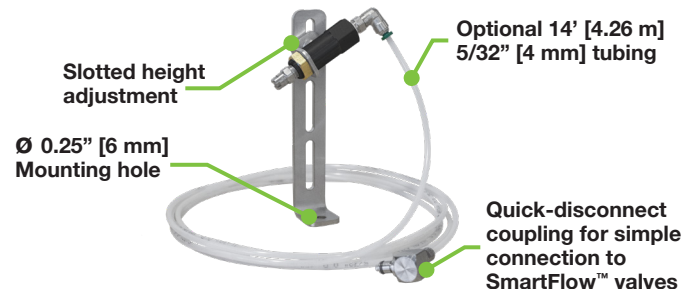

Options

The **In-Die Quick Connect** allows Unist spray nozzles to be permanently mounted to the die, ensuring they remain in position with each die change. Each quick connect is keyed to assure operators reattach the lines correctly. Integral check valves prevent dripping. This is an ideal solution when die-mounted nozzles are necessary.



NEED MORE INFORMATION?

800.253.5462
salessupport@unist.com



Unist, Inc.
4134 36th Street SE
Grand Rapids, MI 49512 USA
U.S. & Canada: 800.253.5462
International: 616.949.0853
Email: salessupport@unist.com